

Analog Board Detailed Design Review Document

Goal: The board is designed to amplify low voltage differential EEG signals in the frequency range of interest. It attenuates unwanted high and low frequency noise using appropriate filtering mechanisms. The key specifications of the board include:

- Single Supply Operation
- Low Power Consumption
- Portable and Lightweight Design
- Adjustable Gain
- Ensure High Signal Integrity

Major Quantitative Specifications:

(See detailed “Quantitative Specifications.pdf” for complete list of specifications and tolerances)

- Input Battery Voltage: 5.6V ($\pm 0.4V$)
- Circuit Operating Voltage : 5.0V ($\pm 0.1V$)
- Analog Board Power Consumption: $\leq 150mW$ ($\pm 10mW$)
- Input EEG Signal Frequency Range of Interest: 0.16Hz to 30Hz
- EEG Input Signal Voltage: 1 μV to 1mV
- Total Analog Board Voltage Gain Range: 4500V/V \pm 1000V/V
- Common Mode Rejection Ratio: $\geq 110dB$
- Amplifier Input Impedance: $\geq 100M\Omega$
- Low Pass Filter (3rd Order Active Bessel Filter) $f_c = 60Hz$
- High Pass Filter (2nd Order Passive RC Filter) $f_c = 0.16Hz$
- Weight: 300 grams (≤ 500 grams)
- Size: 6 inches x 6 inches
- Operating Temperature: 21°C \pm 25°C

Analog Board EEG Signal Flow Diagram:

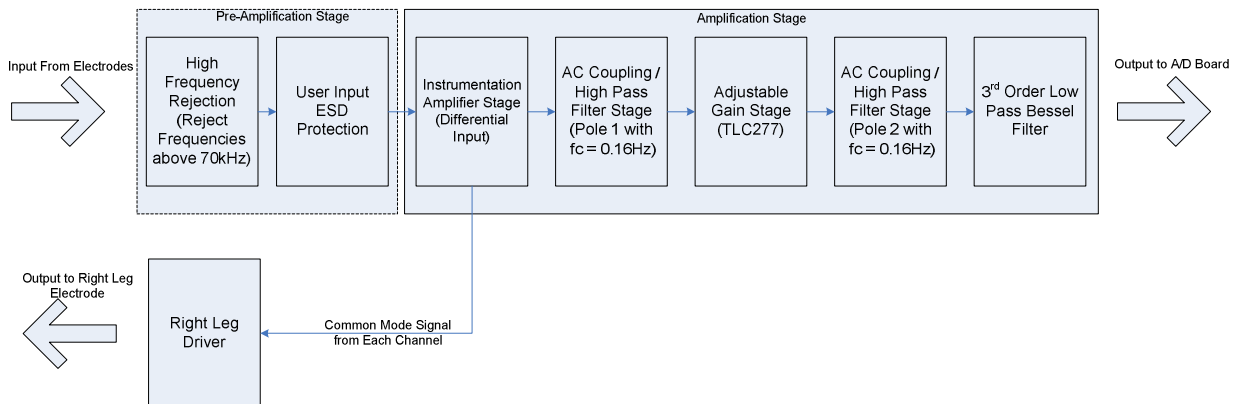

Figure 1: Analog Board Signal Flow Diagram (Note that only 1 channel is shown)

Analysis of Each System Block:

1. High Frequency Rejection:

Goal: To filter out very high frequency content before it enters the amplifier circuit.

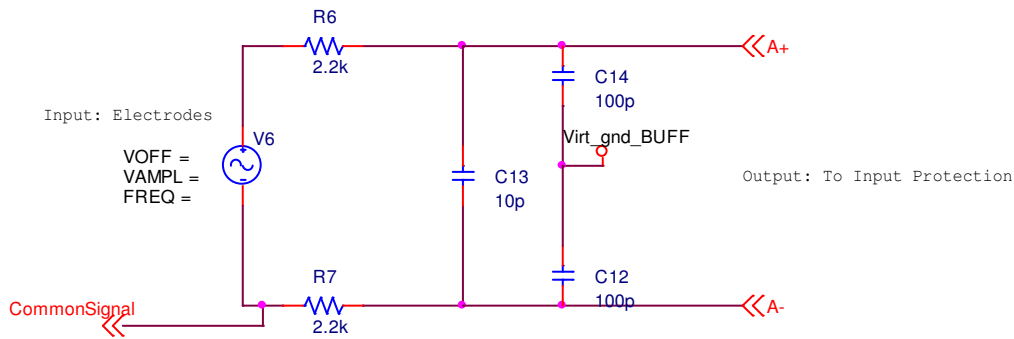

Figure 2: High Frequency Noise Rejection Circuit

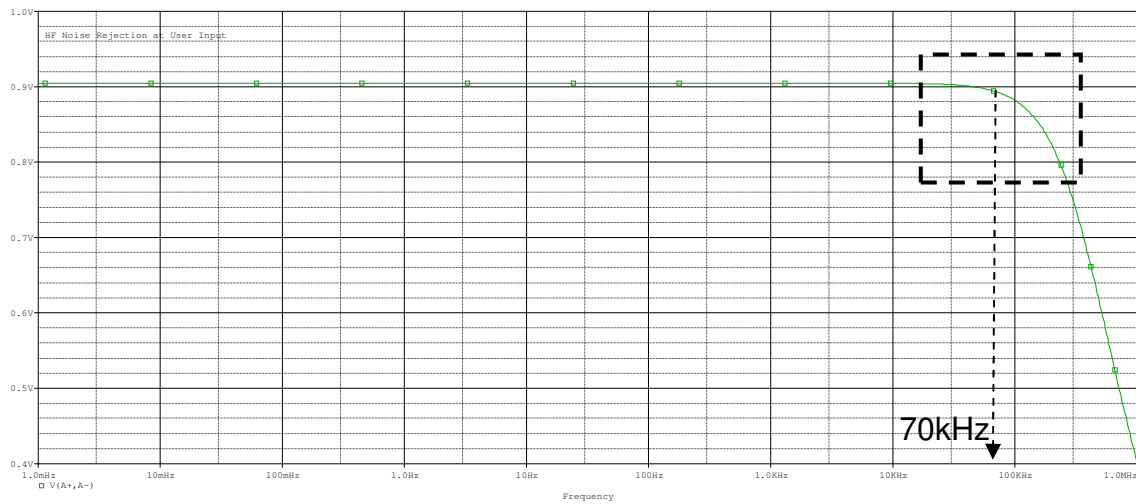

Figure 3: Noise Rejection at User Input (Starts rolling off at ~70kHz)

2. User Input ESD Protection:

Goal: To protect the circuit components from any form of high voltage input from the user end.

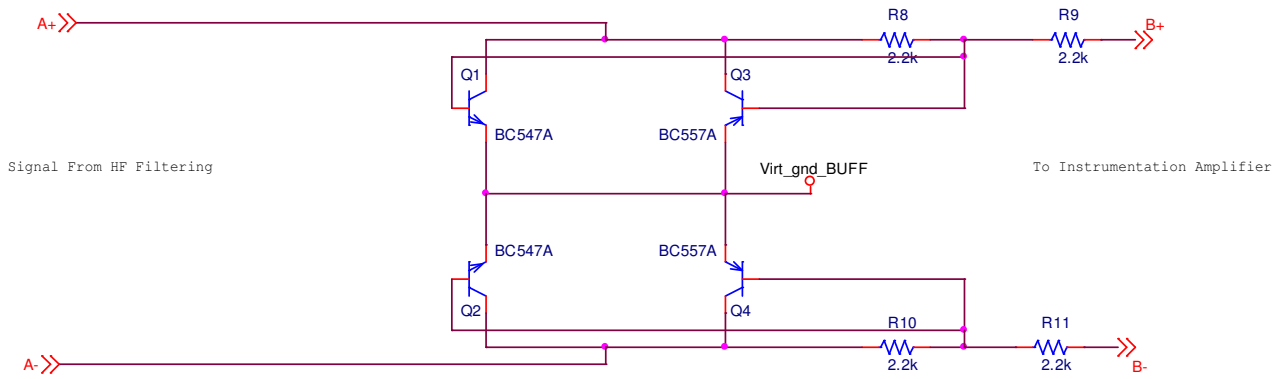

Figure 4: ESD Protection Circuit

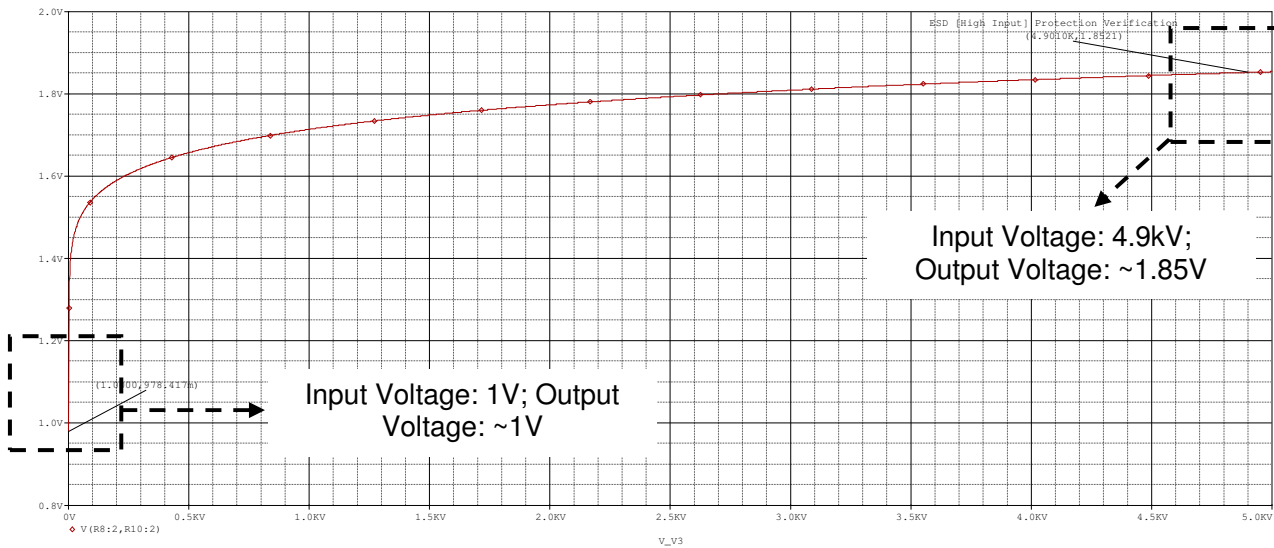

Figure 5: Simulation for ESD Protection Circuit

3. Instrumentation Amplifier Stage:

Goal: Implement a gain of 12V/V on a differential input (EEG signal) using a high precision implementation amplifier.

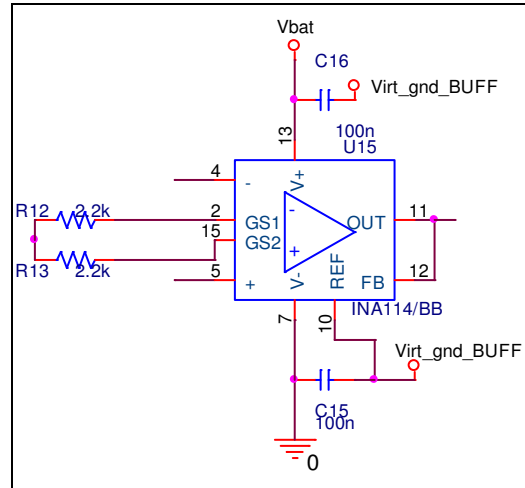

Figure 6: Instrumentation Amplifier Stage (Using the INA114 Instrumentation Amplifier)

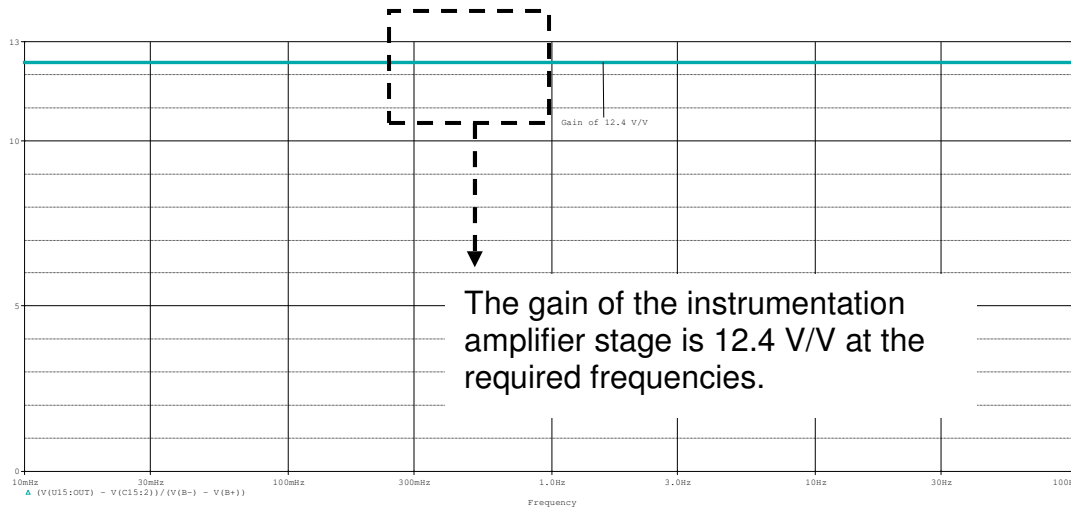

Figure 7: Gain of the Instrumentation Amplifier Stage (Differential)

4. AC Coupling and High Pass Filter Stage:

Goal: Remove DC offsets from the signal and implement a high pass filter with a cutoff frequency of 0.16Hz. This stage will implement the first pole of the high pass filter.

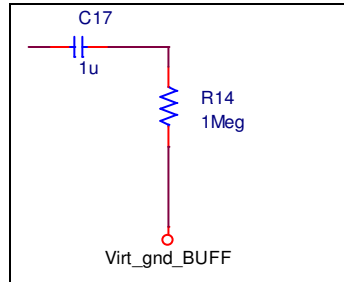

Figure 8: AC Coupling and High Pass Filter Circuit

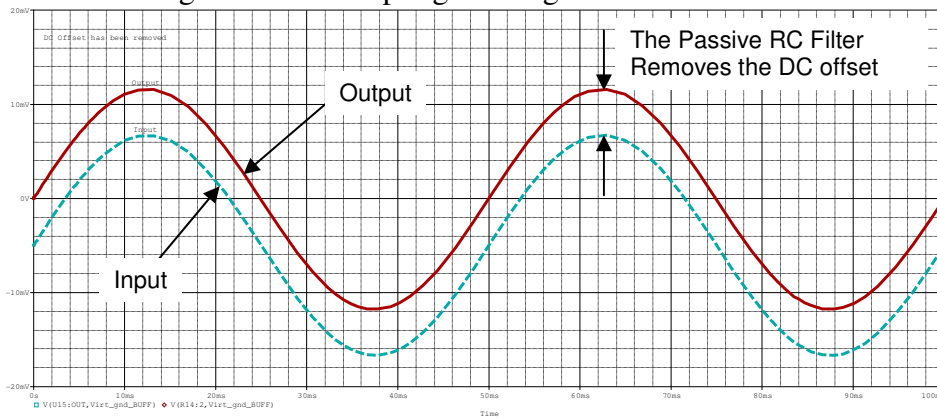

Figure 9: Simulation showing removal of DC offset

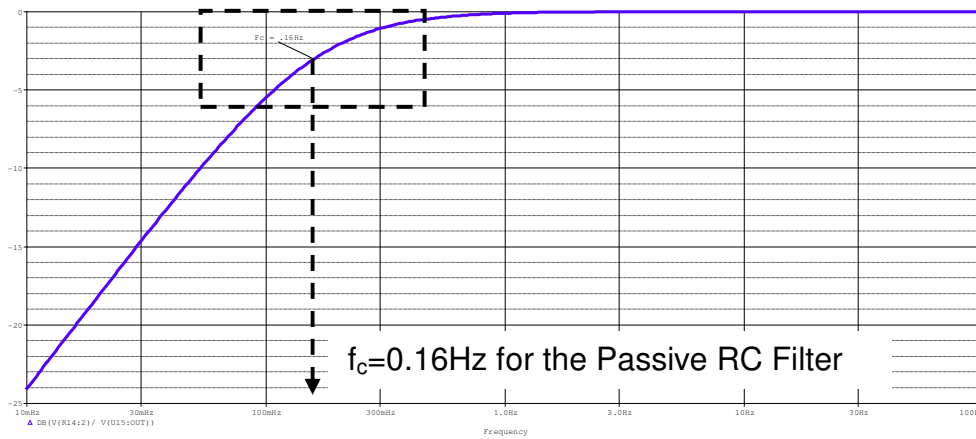

Figure 10: Simulation showing the cutoff frequency at 0.16Hz.

5. Adjustable Gain Stage (TLC277)

Goal: Implement a variable gain ranging from 6V/V to 100V/V using a potentiometer and a TLC277 amplifier.

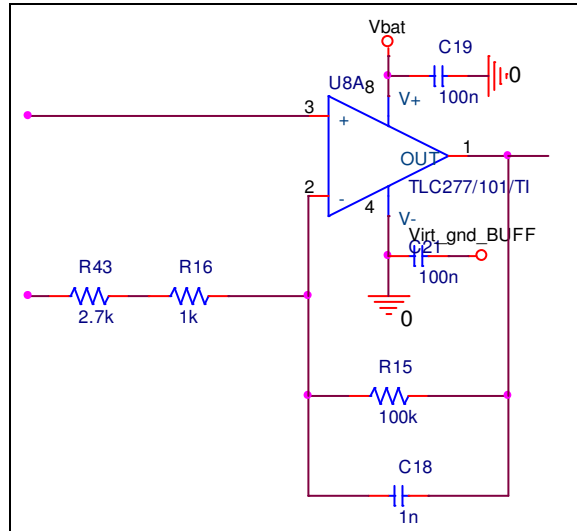

Figure 11: Adjustable Gain Stage Circuit (Using the TLC277 Amplifier)

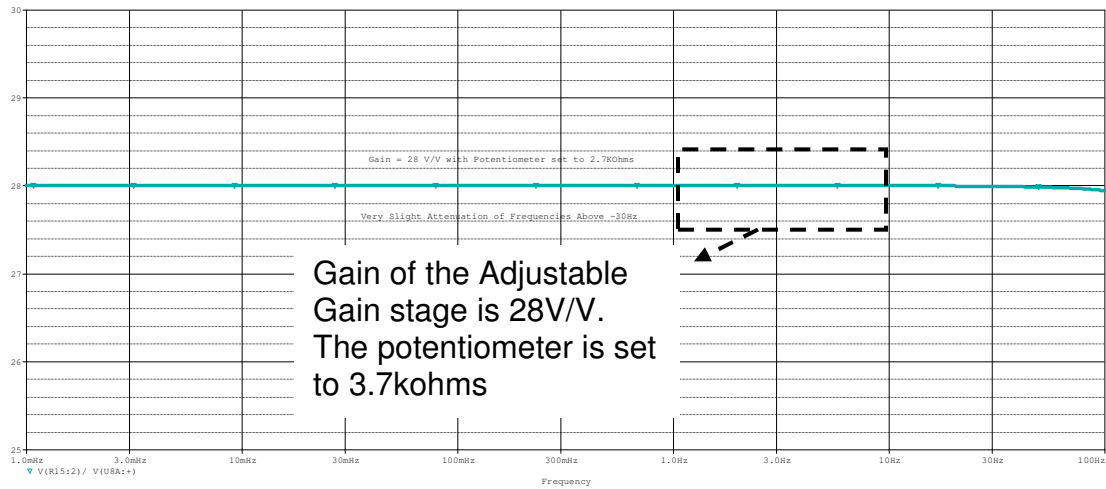

Figure 12: Gain of the Adjustable Gain Amplifier Stage

6. AC Coupling and High Pass Filter Stage:

Goal: Remove DC offsets from the signal and implement a high pass filter with a cutoff frequency of 0.16Hz. This stage will implement the second pole of the high pass filter.

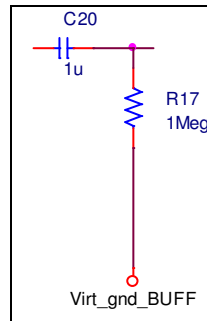

Figure 13: AC Coupling and High Pass Filter Circuit

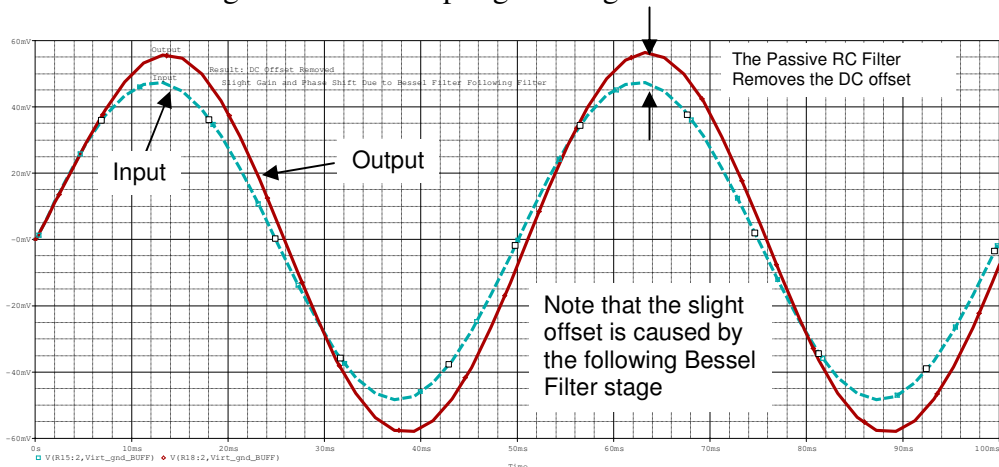

Figure 14: Simulation showing removal of DC offset

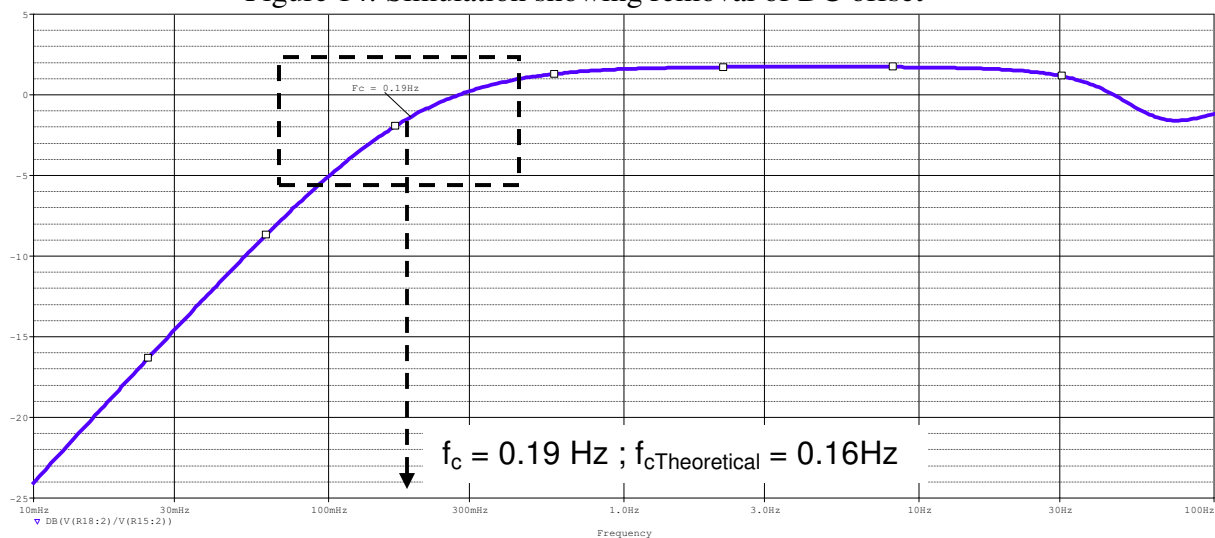

Figure 15: Simulation showing the cutoff frequency at 0.16Hz. (Second Pole of the system at 0.16Hz)

7. 3rd Order Low Pass Bessel Filter Stage:

Goal: Filter out frequencies less than 50Hz and implement a gain of 16V/V using a TLC277 amplifier.

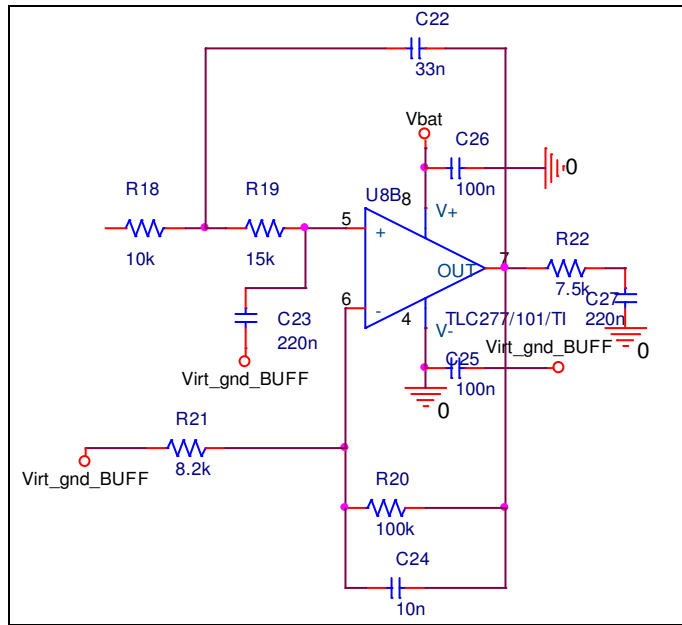

Figure 16: 3rd Order Low Pass Bessel Filter Stage Circuit (Using the TLC277 Amplifier)

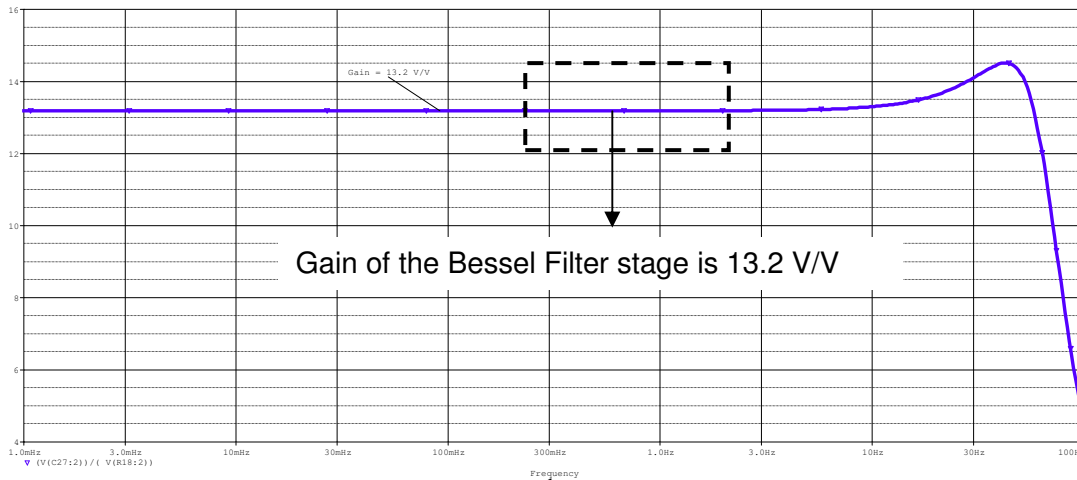

Figure 17: Gain of the 3rd Order Low Pass Bessel Filter

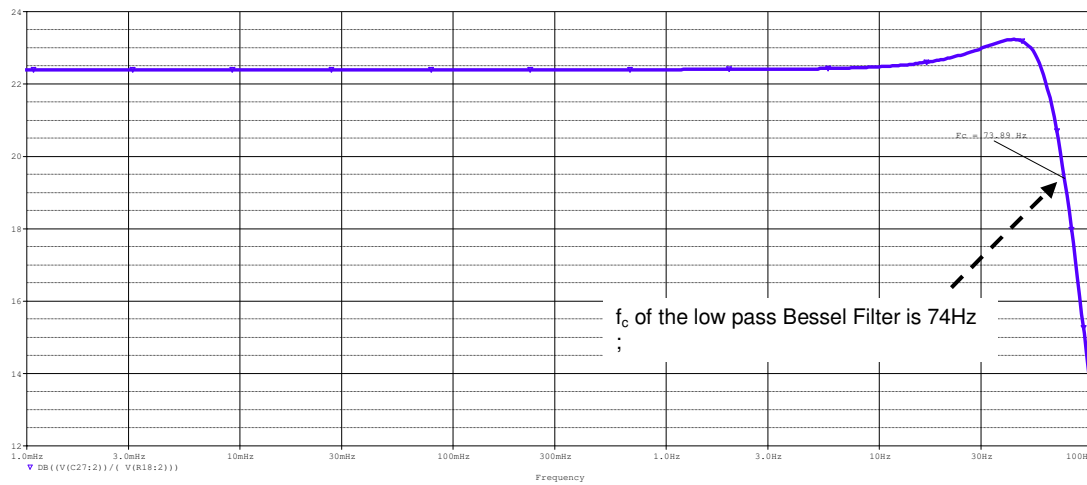

Figure 18: Cutoff Frequency of the low pass 3rd order Bessel Filter

8. Right Leg Driver:

Goal: To increase the CMRR of the analog board.

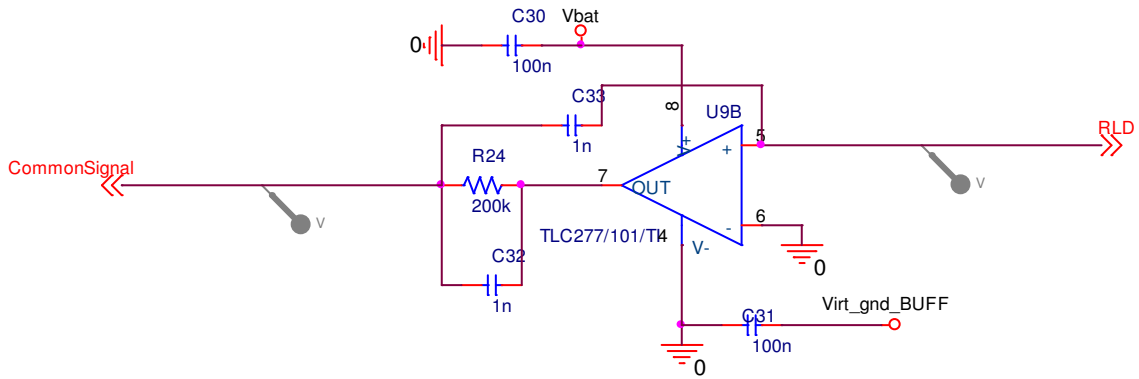

Figure 19: Right Leg Driver Schematic

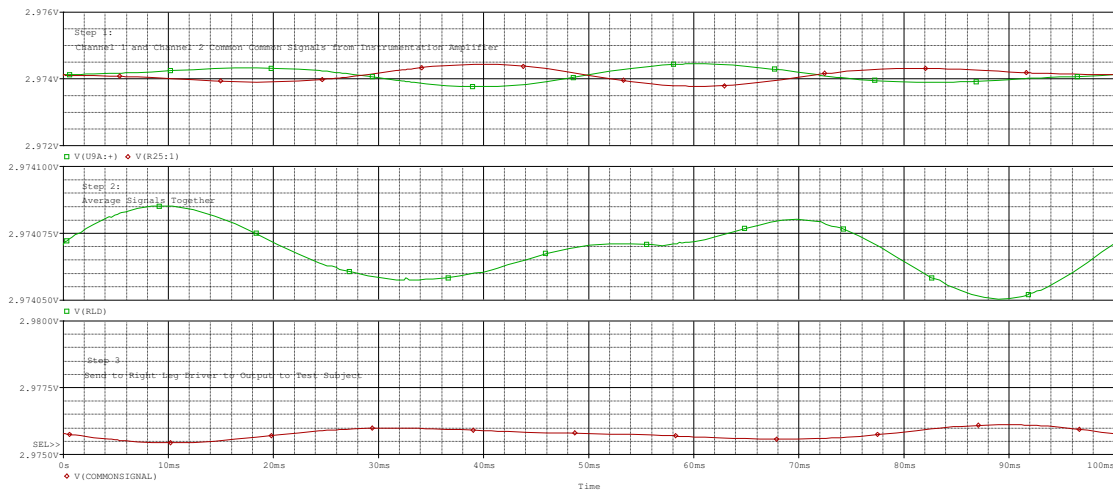

Figure 20: Two Arbitrary Inputs To a Pair of Electrodes (Top); The average of the two signals (Middle); The output of the Right Leg Driver (Bottom)

Complete Analog Board:

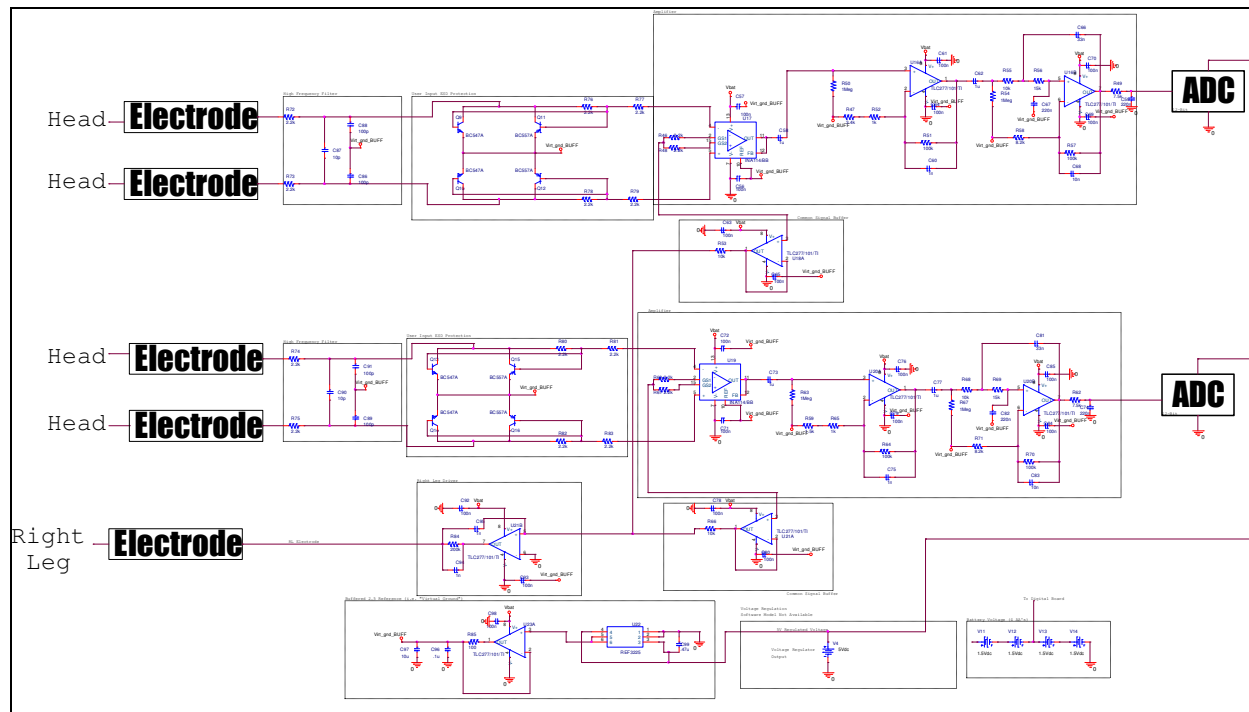

Figure 21: Complete Analog Board Schematic

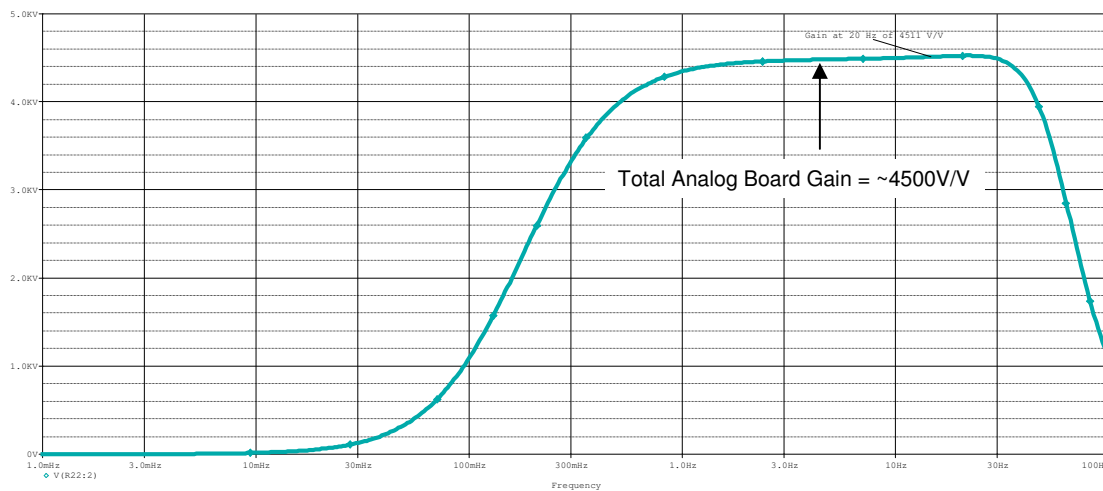

Figure 22: Total Gain of Analog Board

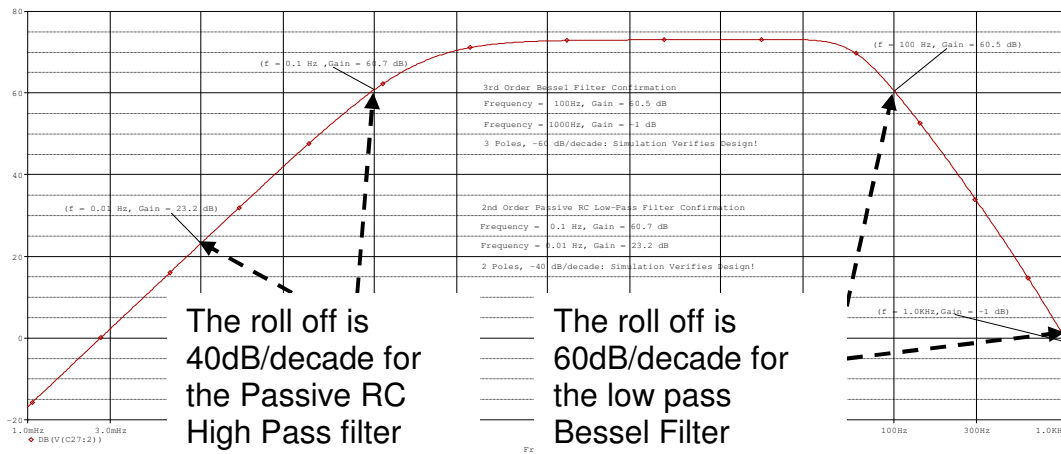

Figure 23: Verification that both high and low pass filters work as designed

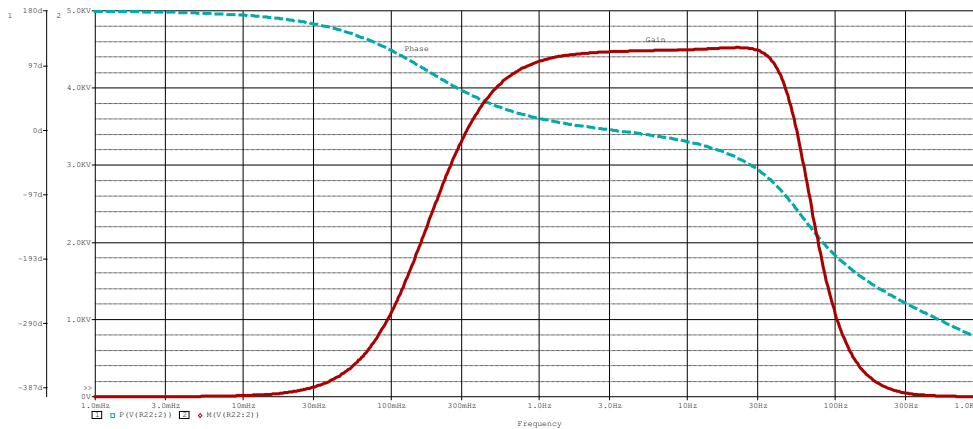

Figure 24: Gain and Frequency Response of the Complete Analog Board

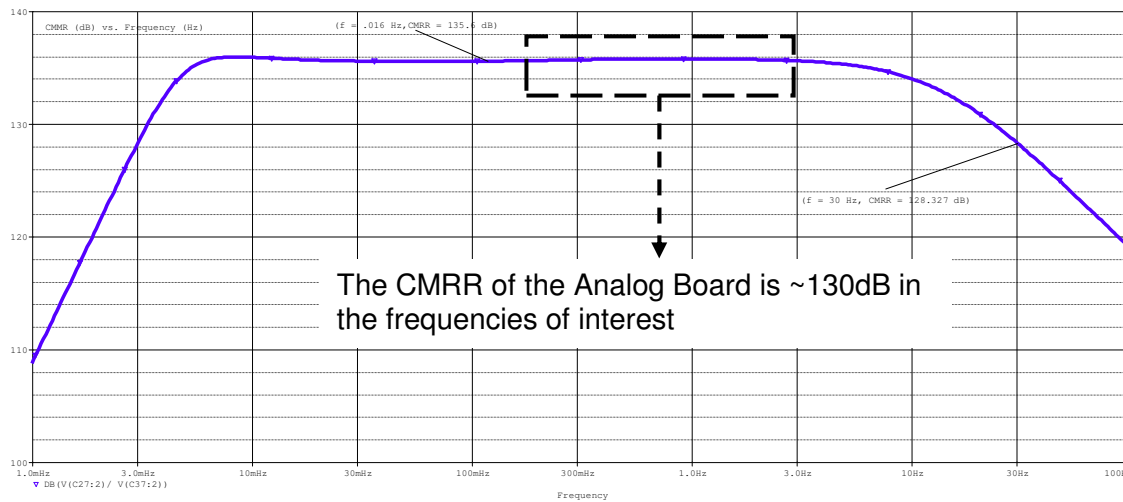

Figure 25: CMRR of the Analog Board

Powering the System:

Analog Board: The analog board will be powered using 4 AA batteries (1.5V each) in series. An REG101-5 regulator will be used to step down the battery voltage to 5VDC (input to the analog board).

Digital Board/Motes: The digital board requires an input range of 2.7V to 3.3V. Two of the four batteries powering the analog board will be used to power the digital board (input voltage of ~3.0V).

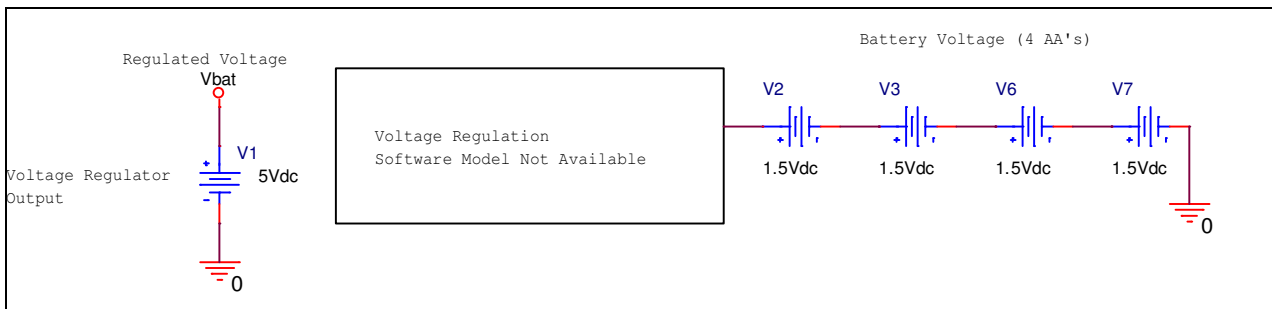

Figure 26: Battery Input with Voltage Regulation

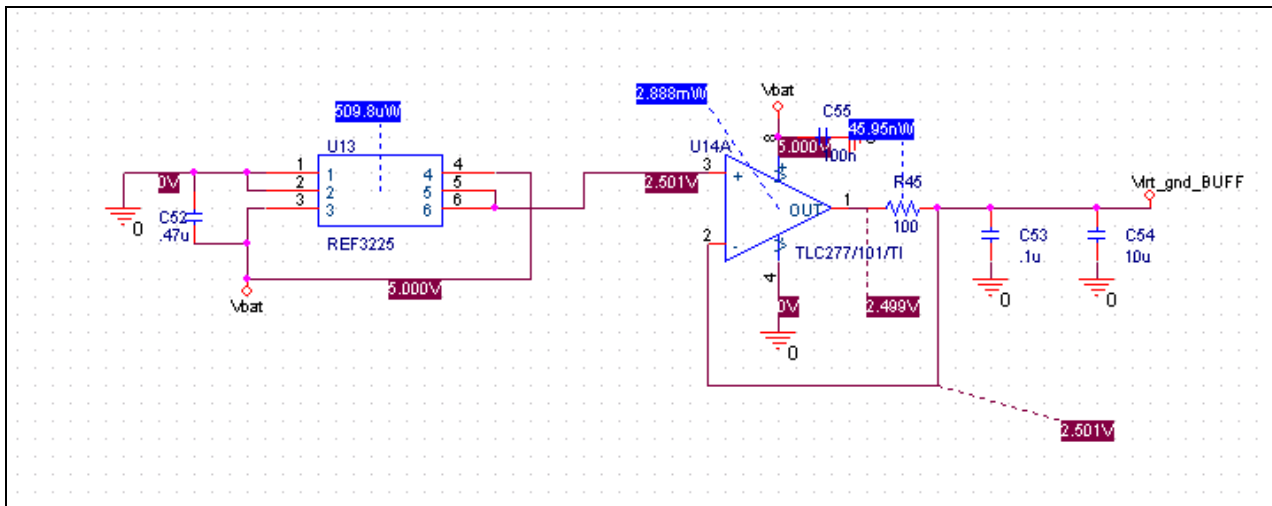

Figure 27: Virtual Ground Buffered using REF3225 and TLC277

Monte Carlo Simulations to Analyze Effects of Part Tolerances and Temperature Variations:

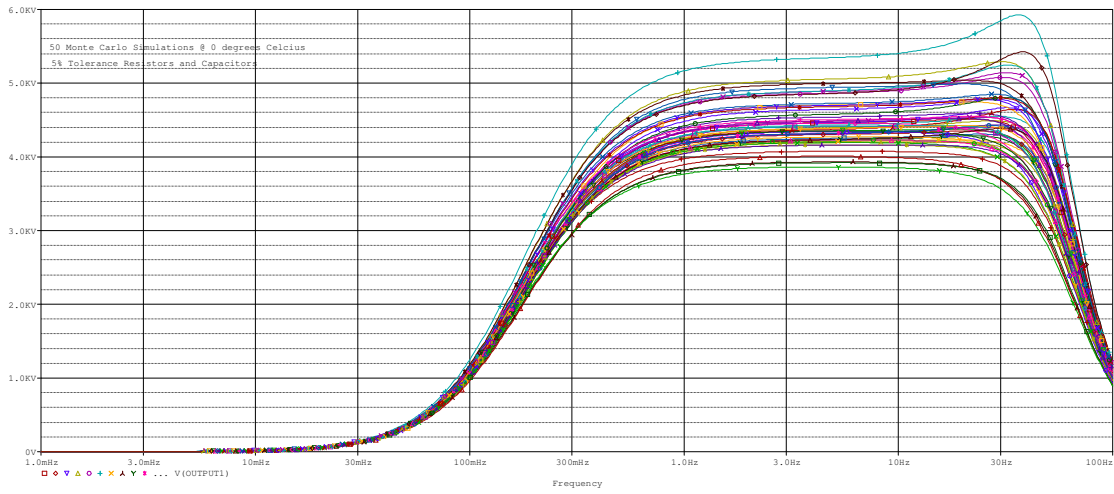

Figure 28: Analog Board Gain with 5% part tolerances at -0.5° C.

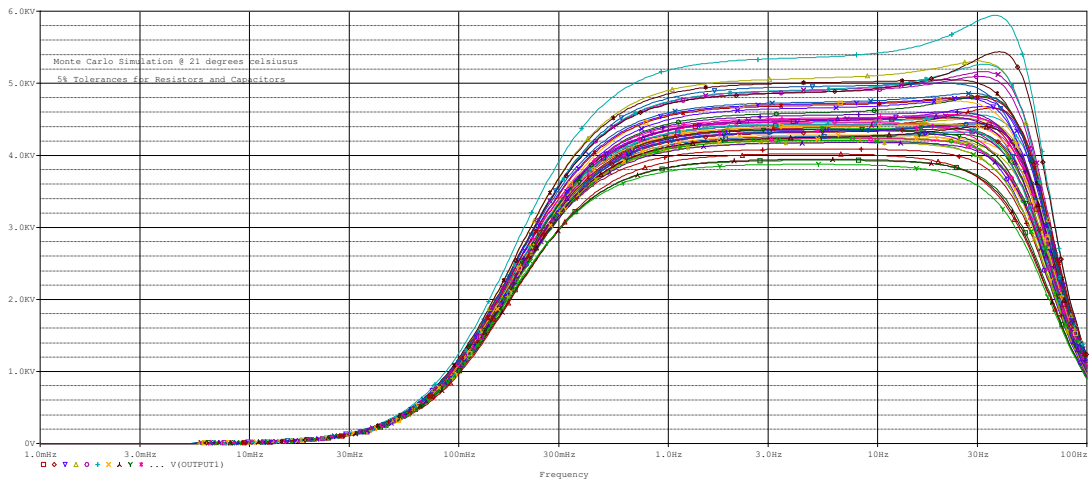

Figure 29: Analog Board Gain with 5% part tolerances at 21° C (room temperature).

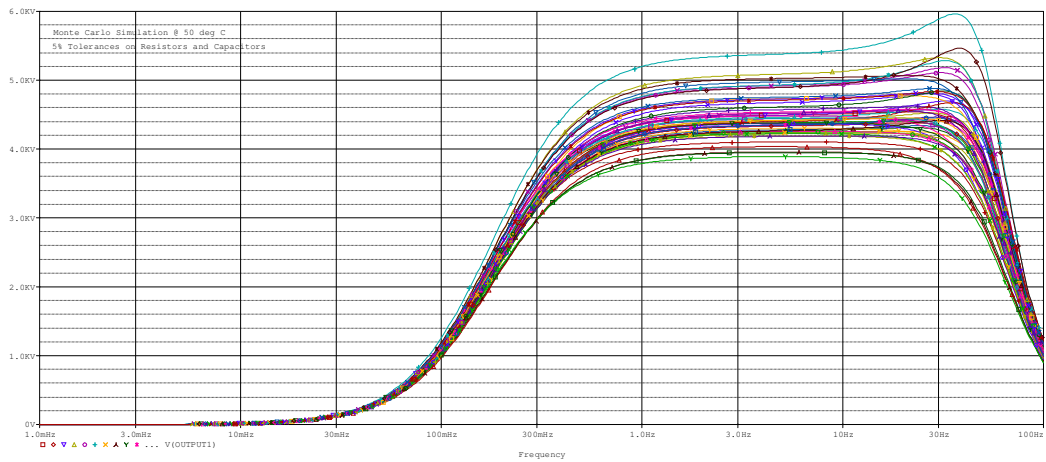

Figure 30: Analog Board Gain with 5% part tolerances at 50° C.

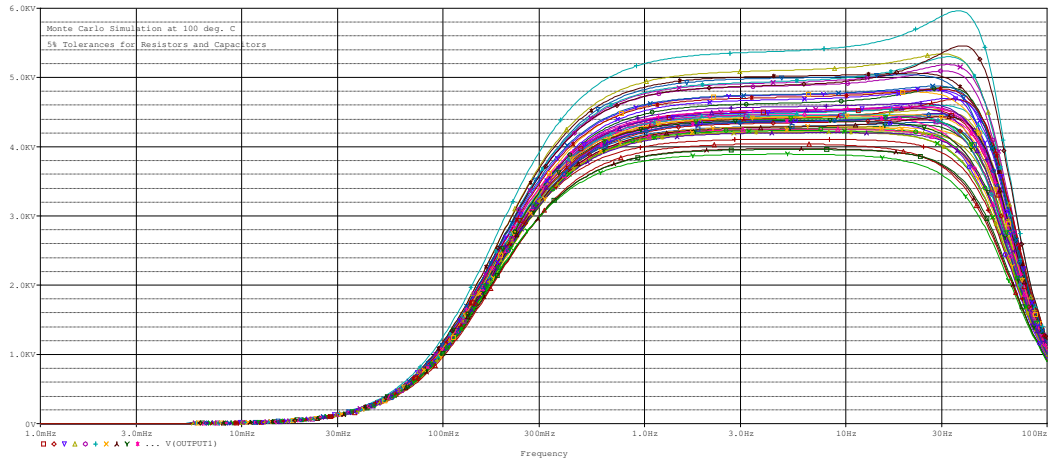

Figure 31: Analog Board Gain with 5% part tolerances at 100° C.

Battery Analysis/Specifications

Energizer e2 Lithium AA, 3000mAh

Classification: "Cylindrical Lithium"

Chemical System: Lithium/Iron Disulfide (Li/FeS₂)

Nominal Voltage: 1.5 Volts

Typical Weight: 14.5 grams (0.5 oz.)

Typical Volume: 8.0 cubic centimeters (0.5 cubic inch)

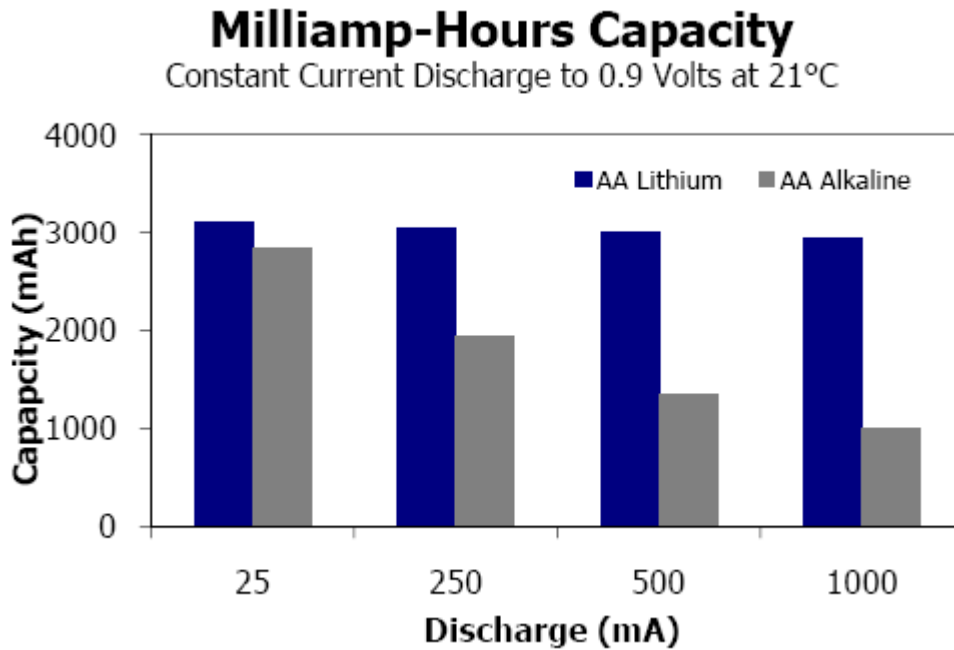

Figure 32: Capacity vs. Discharge showing lithium as the better choice.

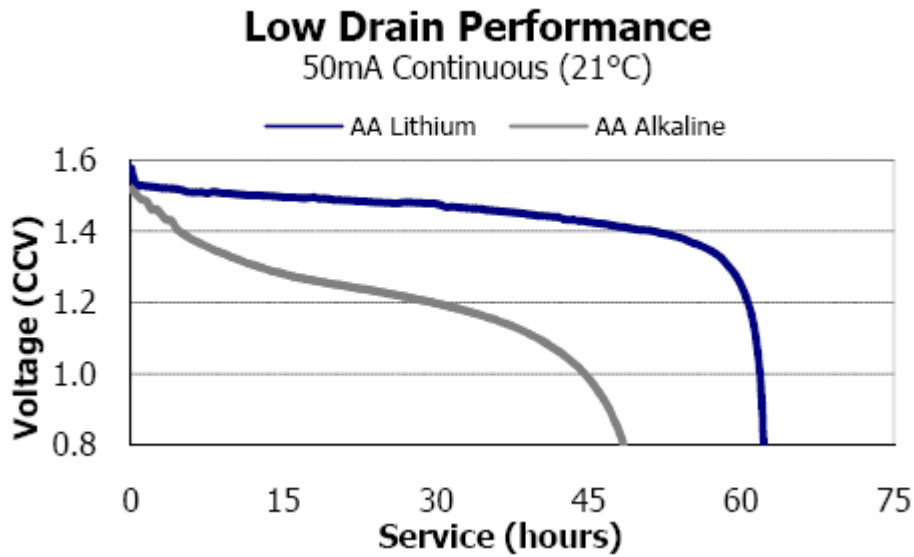

Figure 33: Voltage vs. Service (at 50mA continuous drain) showing lithium as the better choice.

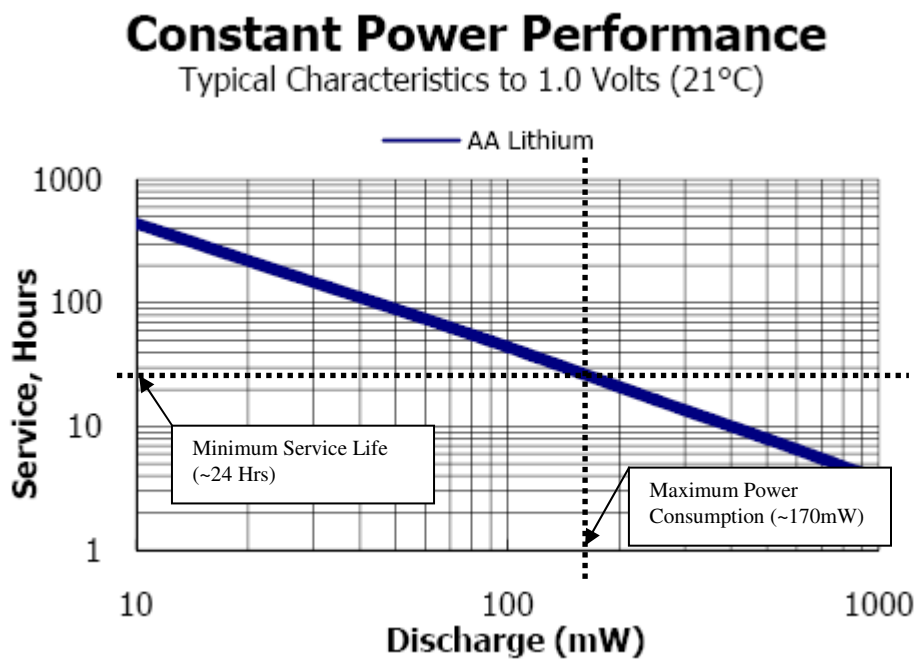

Figure 34: Service Hours vs. Power Discharge. lines indicate our minimum operating time and also our maximum power consumption.