

# A Portable, Low-Power, Wireless Two-Lead EKG System

Thaddeus R. F. Fulford-Jones, Gu-Yeon Wei, Matt Welsh  
Division of Engineering and Applied Sciences, Harvard University

**Abstract**—Sensor devices (“motes”) which integrate an embedded microprocessor, low-power radio and a limited amount of storage have the potential to significantly enhance the provision of emergency medical care. Wearable vital sign sensors can wirelessly monitor patient condition, alerting healthcare providers to changes in status while simultaneously delivering data to a back-end archival system for longer-term storage.

As part of the CodeBlue initiative at Harvard University, we previously developed a mote-based pulse oximetry module which gathers data from a noninvasive finger sensor and transmits it wirelessly to a base station. To expand the capabilities of the mote for healthcare applications we now introduce *EKG on Mica2*, the first custom-designed electrocardiograph sensor board to interface with this platform. We additionally present *VitalEKG*, a collection of software components which allow the capture and wireless transmission of heart activity traces. We present preliminary test results which validate our approach and suggest the feasibility of future enhancements.

**Keywords**—ECG, EKG, Mica2, Mote, Patient Monitor, Wireless Sensor Network

## I. INTRODUCTION

The CodeBlue project at Harvard University has developed a system that incorporates wireless pulse oximetry (“pulseox”) sensors and electrocardiogram (EKG) sensors to continuously monitor and record vital sign and cardiac information from a large number of patients. Ultimately intended for deployment in a hospital intensive care unit (ICU), this technology represents a significant improvement over currently available systems.

Examples of specific intensive care applications are numerous (Fig. 1). For instance, children who are ventilated in a chronic care facility are at risk of developing hypoxemia (insufficient oxygenation of the blood). This is caused by a variety of reasons, such as aspiration, mucous plugging, respiratory infection, altered ventilator settings and disconnection from the ventilator. We introduce key hardware and software components for a wireless sensor network which will allow hospital staff to gather detailed data on the frequency, duration and severity of these hypoxemic events. It is envisaged that such data will ultimately lead to a better understanding of how medical practitioners can intervene to prevent these events and improve patient outcome.

This work has relevance more generally for the treatment of patients who have suffered serious injury and who receive emergency medical care, either from ambulance personnel or at a hospital [1]. In such scenarios, pulseox and heart rate data are considered to be of primary importance, while EKG monitoring, if available, would be a secondary benefit.

This research provides a foundation for future exploration of the use of wireless-enabled non-invasive sensors in a

healthcare environment. Specifically, we demonstrate the integration of an EKG circuit with UC Berkeley’s Mica2 mote to allow the wireless transmission of continuous cardiac rhythms. Such data could ultimately be received by a physician’s PDA or by a personal computer located at a nurse station.

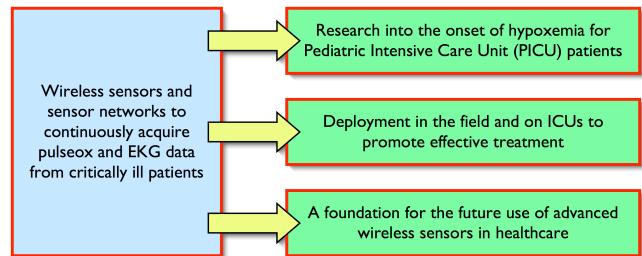

Fig. 1. Potential future uses of this technology.

## II. BACKGROUND

Two different types of electrocardiography machine are found in general use today. The first and more prevalent, the “standard EKG,” generally involves the connection of between twelve and fifteen leads to a patient’s chest, arms and right leg via adhesive foam pads. The device records a short sampling (not more than thirty seconds) of the heart’s electrical activity between various pairs of electrodes [2]. Each pair of leads provides a unique and detailed picture of the cardiac rhythm, an individual echo of the heart’s electrical impulses as they are conducted through surrounding tissue. An experienced cardiologist can rapidly interpret a standard EKG tracing to diagnose a wide range of possible ailments. However, because standard EKG traces only represent a short sampling of patient data, cardiac conditions which are irregular or intermittent may not be identifiable. Such sporadic abnormalities are often presented by ICU patients who have suffered severe injuries; these cardiac signals may indicate a need for urgent medical intervention.

To address this shortcoming of the standard EKG, many hospitals currently use “continuous electrocardiogram telemetry” to monitor patients in intensive care. This involves the deployment of a three-electrode EKG device to evaluate a patient’s cardiac activity for an extended period. The amplified heart signals are either displayed on a screen or printed onto a roll of paper adjacent to the patient’s bedside. A physician may advise continuous monitoring if there is a chance that a patient has cardiac problems such as an irregular heartbeat, or arrhythmia, that require close monitoring or that occur intermittently, maybe only once or twice a day. Continuous telemetry may also be useful as a means of alerting healthcare staff to the first signs of deterioration of a patient’s condition.

Many EKG machines, both standard and continuous, are marketed as “portable” – but this does not always indicate that they are small and unobtrusive. By contrast, most such appliances receive power from an electrical outlet and are sufficiently heavy that they must be mounted on a cart and wheeled from one location to the next. Wireless sensor networks have the potential to significantly improve this situation. Motes are particularly advantageous because of their low cost, small volume, rapid deployment and ease of integration with existing hospital computer systems.

We have selected the Mica2 mote, developed by UC Berkeley and manufactured by Crossbow Technology, Inc. [3] as the preferred hardware platform for our sensor network research. The Mica2 is the company’s third generation of tiny, wireless smart sensors. Significantly smaller than existing portable hospital monitors, the mote comprises an embedded microcontroller, low-power radio, and a modest amount of local storage in a package measuring 5.7cm by 3.2cm by 2.2cm. Powered by 2 AA batteries, the device consumes roughly 60mW of power when active, and features a battery lifetime of a few days, assuming continuous operation. In the event constant monitoring is not required, the Mica2 can enter an ultra low-power standby mode which limits the current draw to just 10µA and increases the battery lifetime to over 20 years. In practice, duty cycling can be employed to achieve a balance between power consumption and performance such that the battery life is reasonable for the intended application.

The Mica2 radio is technologically distinct from commercially-available wireless chips which use 802.11b and Bluetooth. The Chipcon CC1000 [4] operates in the ISM band at either 433MHz or 916MHz with a variable transmission power between -20 dBm and +10dBm. Devices

operating in this frequency and power range should be safe for operation in medical environments, and we are currently planning interference experiments to confirm this. The maximum data rate is 76,800 bits per second (bps) with a practical indoor range of approximately 20-30m. The mote’s limited bandwidth and computational capabilities preclude the use of Internet connectivity protocols such as TCP/IP, DNS, and ARP.

The Mica2 motes run a specialized event-driven operating system, called TinyOS [5], that specifically addresses the concurrency and resource management needs of sensor nodes. Applications may be written for TinyOS using nesC [6], an extension to the C programming language which is designed to embody the structuring concepts and execution model of the operating system.

Our research showcases the potential of wireless sensor networks in healthcare by demonstrating the integration of an EKG circuit with a Mica2 mote to allow the wireless transmission of continuous cardiac rhythms. Such data could ultimately be received by PDAs, desktop PCs or other wireless-enabled devices in a multitude of healthcare scenarios. This research is twofold, comprising both hardware that interfaces an EKG circuit with the Mica2 platform and software that reliably captures electrocardiograph data and transmits it wirelessly to a nearby receiver. The former is referred to as *EKG on Mica2* while the latter is termed *VitalEKG*.

### III. HARDWARE

The key hardware requirements for an EKG circuit to interface with the Mica2 mote are outlined in Table 1.

TABLE I  
KEY HARDWARE REQUIREMENTS FOR THE *EKG ON MICA2* CIRCUIT

Number	Requirement	Justification
1	The circuit shall be capable of operating from a supply of +3V.	When fabricated as a mote expansion board, the circuit will be powered by the Mica2’s 3-Volt batteries. Voltage step-up mechanisms are notoriously unreliable and should be avoided whenever possible.
2	The output signal of the EKG shall be biased around +1.5V.	Minimizes the probability of large signals being clipped against the power or ground supply rails.
3	The circuit shall have a current draw of no more than 20mA when operational.	Given that power will be sourced from the Mica2’s supply, it is essential to maximize battery lifetime. 20mA is an average current requirement for many commercial EKG devices.
4	The circuit shall provide adequate amplification of signals which are in the range -5.0mV to +5.0mV	Cardiac tissue is not capable of generating signals which are greater than 5.0mV in magnitude.
5	The amplification circuitry shall provide a Common Mode Rejection Ratio (CMRR) of better than 60dB.	This figure matches the CMRR standard of commercially available products with similar functionality. [7]
6	When fabricated as a Mica2 sensor board, the circuit shall receive power from a digital I/O pin of the expansion connector.	This allows the mote to automatically deactivate the EKG circuitry when its use is not required, thereby minimizing average power consumption.
7	When fabricated as a Mica2 sensor board, an upward-facing expansion connector shall be made available. In addition, no component shall extend more than 3.3mm above the upper surface of the board.	These requirements permit the possibility of future simultaneous deployment of the BCI pulseox finger sensor and <i>EKG on Mica2</i> from a single mote. This would require modular stacking of the two boards.
8	When fabricated as a Mica2 sensor board, the circuit shall leave accessible ports 1, 2, 27, 28, 29, 30, 42, 50 and 51 of the expansion connector.	

At the heart of the *EKG on Mica2* design is Texas Instruments' INA321 integrated circuit (IC), a micropower single-supply CMOS instrumentation amplifier with a very favorable CMRR of 94dB. The circuit, which uses tiny surface-mount parts in order to minimize noise and current draw, also consists of three operational amplifiers from a single CMOS quad op-amp package, together with a multitude of resistors and capacitors. It is based on a design provided in TI's datasheet for the INA321 component and incorporates design elements from a four-lead EKG system built by researchers at MIT's Media Lab as part of the Every Sign of Life project [8].

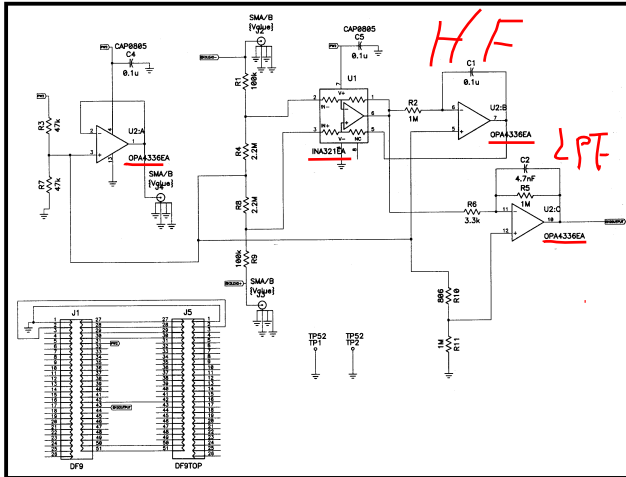

Fig. 2. Schematic of the *EKG on Mica2* circuitry

The schematic (Fig. 2) consists of a biasing divider (R3, R7) which splits the supply in half and connects to the lower left chest lead (red) as a means of setting the patient to the correct potential. The other two leads (colored white and black, respectively) receive signals from the patient's upper chest and transmit the resulting differential signal to the INA321 device. This component amplifies the difference by a factor of 5 (internally configured), while rejecting almost all of the common-mode noise. The INA321 is configured with a high-pass feedback filter (C1, U2:B) to dynamically correct

any DC shift that may occur over time. Its output passes to a final operational amplifier which further amplifies the signal and acts as a low-pass filter.

Our custom analog expansion board is pictured in Fig. 3; a cable carrying the three separate patient leads exits to the right of the photograph. The circuit is intended to take readings from these electrodes and deliver the resulting trace to the mote's built-in ADC via the 51-pin expansion connector.

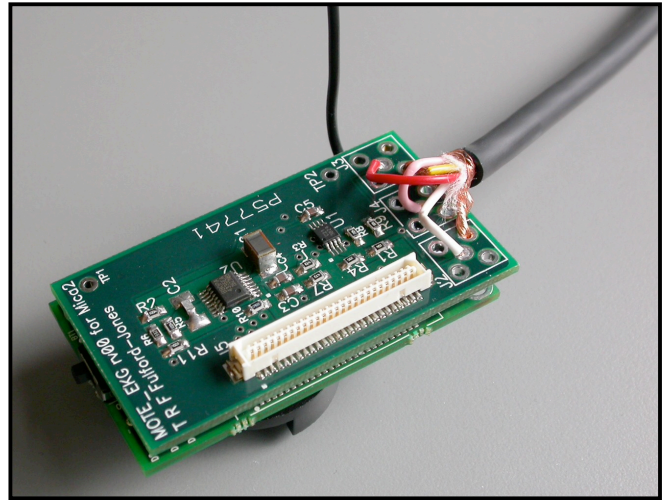

Fig. 3. The *EKG on Mica2* printed circuit board attached to a Crossbow mote (barely visible underneath). Dimensions: 5.5cm by 3.2cm

### III. SOFTWARE

The *EKG on Mica2* hardware requires appropriate software to enable the mote to digitize the resulting EKG signal at a sufficiently high rate and transmit it over the RF antenna to a base station. The software requirements and justifications are detailed in Table 2.

TABLE 2  
KEY SOFTWARE REQUIREMENTS FOR *VITAL EKG*

Number	Requirement	Justification
1	The software shall sample the EKG signal using the built-in Mica2 ADC.	The Mica2 ADC is capable of performing 10-bit digitizations, which is comparable in accuracy to the specifications of commercial EKG devices.
2	The signal shall be sampled at a rate of not less than 120Hz.	This figure matches the sample rate of the commercially available BCI Oximeter/EKG/Respiration Board 71272A2.
3	The software shall wirelessly transmit the <i>EKG on Mica2</i> signal in such a way that no loss of data occurs.	It is essential that <i>VitalEKG</i> captures all information since medics may be interested in intermittent abnormalities which can occur at any time.
4	Transmission of each data packet should occur regularly and no more frequently than once every 250 milliseconds.	Since other motes may be in the vicinity during the operation of <i>VitalEKG</i> , it would not be appropriate to broadcast continuously and risk corrupting the information being sent to and from other devices.
5	Java software at the base station shall receive the EKG data and decode it as necessary to regenerate the original tracing.	If data is encoded on the mote before transmission, it is equally important to decode upon receipt at the base station.

Due to the mote's limited processing capabilities, a simple differential encoding scheme was selected. To achieve the goal of a 120Hz sample rate with only four transmissions per second it was necessary to eliminate all potential sources of broadcast and storage inefficiency.

By default, TinyOS stores ten-bit ADC readings as sixteen-bit unsigned integers; accordingly, *VitalEKG* first performs bitshift operations to concatenate multiple readings into as small a memory space as possible. In addition, *VitalEKG* differentially encodes readings such that each transmission contains a single unsigned ten-bit start value followed by twenty-nine six-bit differential values. Given four transmissions every second, the required 120Hz rate is achieved.

#### IV. DISCUSSION

Expert assessment of the analog *EKG on Mica2* circuit under controlled conditions suggested that the circuit's performance was indeed comparable to that of a commercial EKG system [9]. Oscilloscope output of the circuit is shown in Fig. 4.

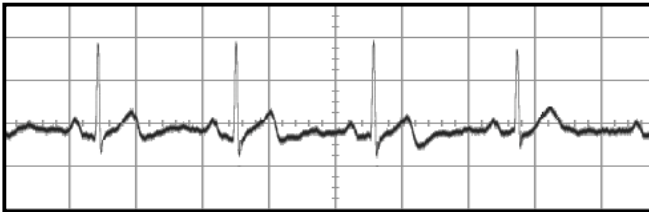

Fig. 4. Clinically accurate output of the *EKG on Mica2* circuit

Integrating *EKG on Mica2* with the *VitalEKG* software yielded promising preliminary results and confirmed that a 120Hz sample rate could indeed be achieved using the differential encoding scheme. However, the resulting received waveform was non-optimal owing to the fact that the mote's radio broadcasts caused interference with the analog EKG capture circuitry. This unexpected shortcoming can likely be remedied by the use of appropriate radio shielding techniques.

#### V. CONCLUSION

The integration of *EKG on Mica2* and *VitalEKG* with the Mica2 platform represents a promising advance and demonstrates the feasibility of EKG data collection by wireless sensor networks.

Possible future development work includes enhancement of *EKG on Mica2* with the addition of further noise-filtering hardware and the incorporation of secure routing and prioritization into the *VitalEKG* software. Planned CodeBlue development efforts also include the integration of a pulseox finger sensor and EKG system onto a single mote and the implementation of *ad hoc*, multi-hop routing for this system.

#### REFERENCES

- [1] Conversation with John Conceison, Executive Director of South Middlesex EMS Consortium
- [2] V. Fuster (ed.), *Hurst's The Heart, Tenth Edition* New York, NY: McGraw-Hill Medical Publishing, 2001, ch. 11.
- [3] Crossbow Technology, Inc. [www.xbow.com](http://www.xbow.com)
- [4] Chipcon, [www.chipcon.com](http://www.chipcon.com)
- [5] Jason Hill, Robert Szewczyk, Alec Woo, Seth Hollar, David E. Culler, and Kristofer S. J. Pister. "System architecture directions for networked sensors." In *Architectural Support for Programming Languages and Operating Systems*, pages 93–104, 2000.
- [6] David Gay, Phil Levis, Rob von Behren, Matt Welsh, Eric Brewer, and David Culler, *The nesC Language: A Holistic Approach to Networked Embedded Systems*, PLDI'03.
- [7] EKGCard™ by QRS Diagnostic, [www.qrsdiagnostic.com](http://www.qrsdiagnostic.com)
- [8] MIT Media Laboratory's "Every Sign of Life" project: [vadim.www.media.mit.edu/esl/esl.html](http://vadim.www.media.mit.edu/esl/esl.html).
- [9] Assessment by Michael D. Klein, M.D., Clinical Professor of Medicine at Boston University.